

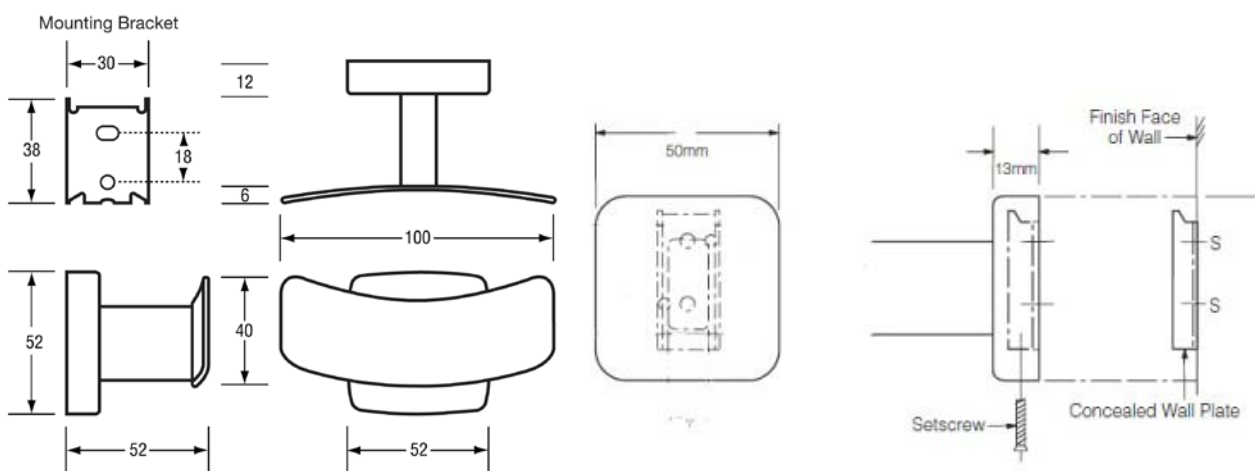

MATERIAL SPECIFICATION & INSTALLATION GUIDE

PRODUCT ITEM CODE & DESCRIPTION

ML 211 ~ STAINLESS STEEL DOUBLE ROBE



COMPONENT MATERIALS:

#304 Grade Stainless Steel, Exposed Surfaces #3 (Satin) or #4 (Bright) Finish
Options Available / Hook (2.8mm material) Welded to Support Arm & Mounting Flange
(1.6mm material) / Concealed Fix Wall Plate (1.6mm Material)

DIMENSIONS:

Overall ~ 92mm W x 52mm H x 52mm D

INSTALLATION:

1. May be subject to Australian Building Code Regulations for able bodied and/or disabled use as may be applicable, locate height & mark on wall. It is recommended that the unit is installed whereby it clears any other fixtures by at least 50mm
2. Remove grub screw from underside of Mounting Flange, remove Mounting Plate and then place a small amount of "wet area" rated silicone sealant to rear, around the full perimeter (ensures rigid fitment), then secure to wall surface with appropriate screws/wall-plugs
3. Clean off any excess silicone and leave to cure/set for at least 12 hours before use
4. Secure unit by hanging Flange/Hook in place and secure with set-screw

NOTE: Not recommended for use with materials exceeding a gross weight of 8kg

These units should only be installed by a competent tradesperson and Metlam Australia takes no responsibility for any damage to walls or fixtures due to incorrect installation.