

MATERIAL SPECIFICATION & INSTALLATION GUIDE

PRODUCT ITEM CODE & DESCRIPTION

102 ~ DIE CAST ROBE/COAT HOOK

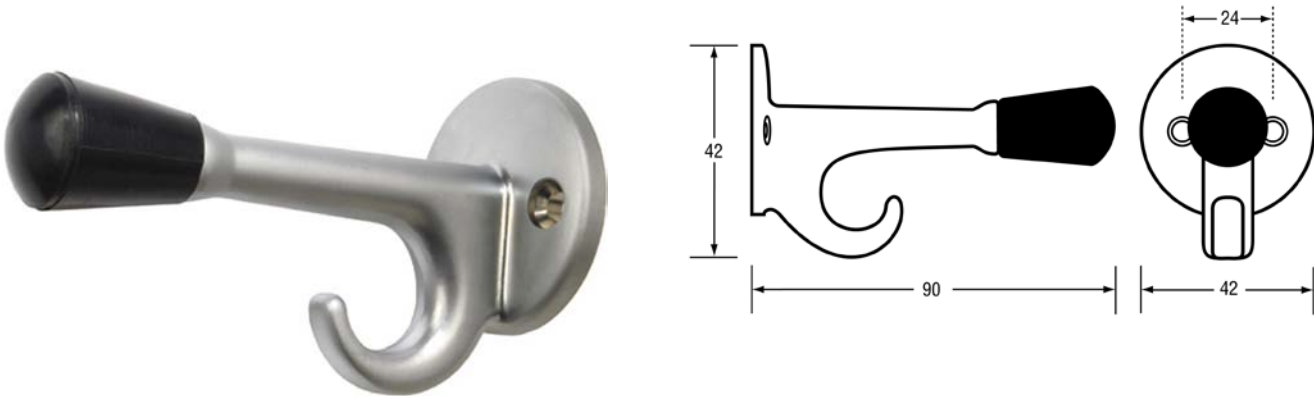

COMPONENT MATERIALS/SPECIFICATION:

Die Cast Zinc Body – Satin Chrome Finish / Exposed Fix Mounting / Rubber Bumper

DIMENSIONS:

Overall ~ 42mm W x 42mm H x 90mm O/A D

INSTALLATION:

1. May be subject to Australian Building Code Regulations for able bodied and/or disabled use as may be applicable. It is recommended that any individual unit is installed whereby it clears any other fixtures by at least 150mm and not carry loads any greater than 8kg
2. Locate fixing height, position - check level & mark on wall / door using mounting holes.
3. Drill mounting holes and install appropriate wall plugs / anchors
4. It is recommended to cover fixing screw thread with a small amount of silicone to ensure fixing tension and long term durability and also to minimise tampering
5. Loosely secure to wall / door surface using appropriate screws / fixings
6. Check level and tighten/secure screws /fixings

These units should only be installed by a competent tradesperson and Metlam Australia takes no responsibility for any damage to walls or fixtures due to incorrect installation.