

NOTES
ALL DIMENSIONS NOMINAL

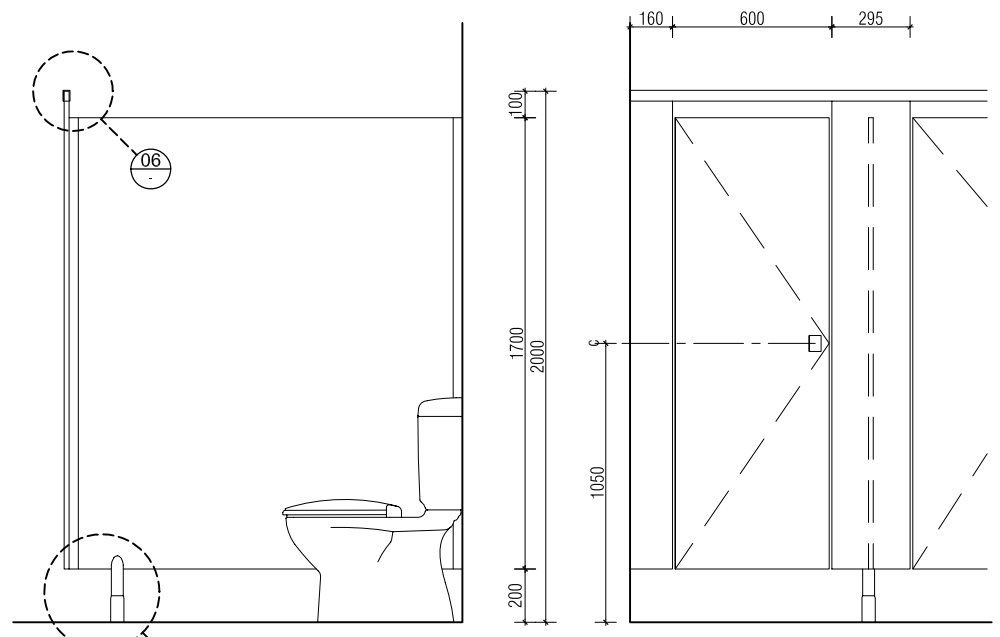

02 ELEVATION
1:10

03 ELEVATION
1:10

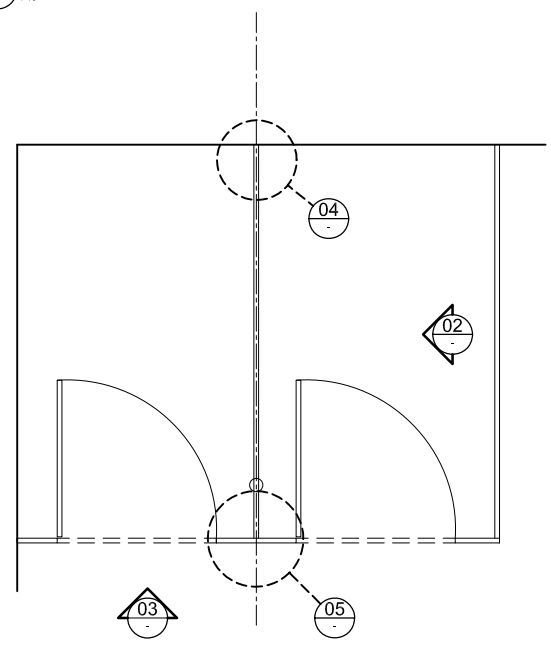

01 PLAN
1:10

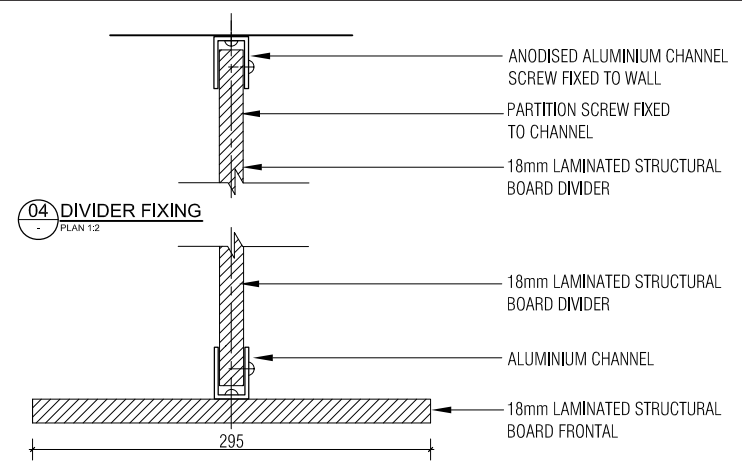

04 DIVIDER FIXING
PLAN 1:2

05 FRONTAL FIXING
PLAN 1:2

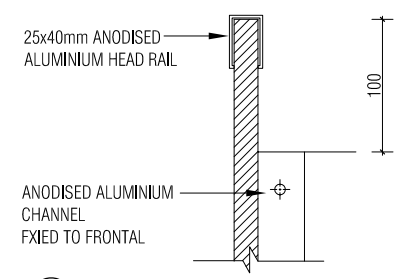

06 HEAD RAIL
DETAIL 1:2

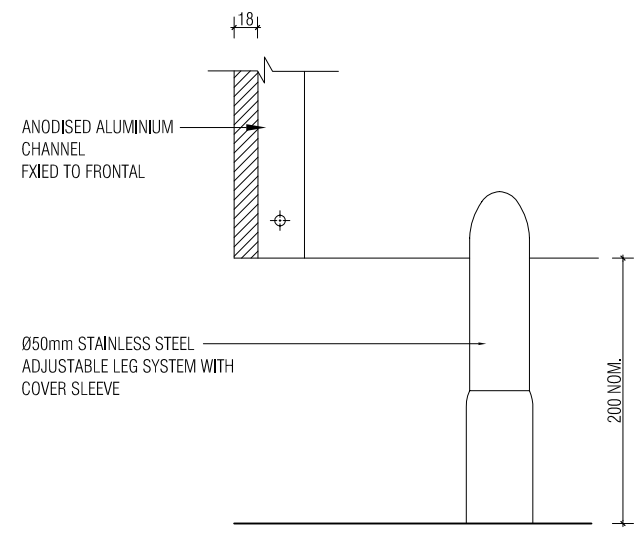

07 FLOOR LEG
SECTION 1:2



Kirkbuild Systems Pty. Ltd.

64a River Road
Redbank QLD 4301
PO Box 101 Redbank
QLD 4301
Ph: 1300 547 528
Fax: (07) 3818 2273
admin@kirkbuild.com.au
www.kirkbuild.com.au

JOB DESCRIPTION
KIRKBUILD INVINCIBLE 1A

DRAWING DESCRIPTION
18mm LAMINATED MRMDF
LEG FLOOR MOUNTED
PARTITION SYSTEM

SCALE DATE
AS SHOWN JAN 14

DRAWING NO. ISSUE
1A 01