

02 ELEVATION
1:10

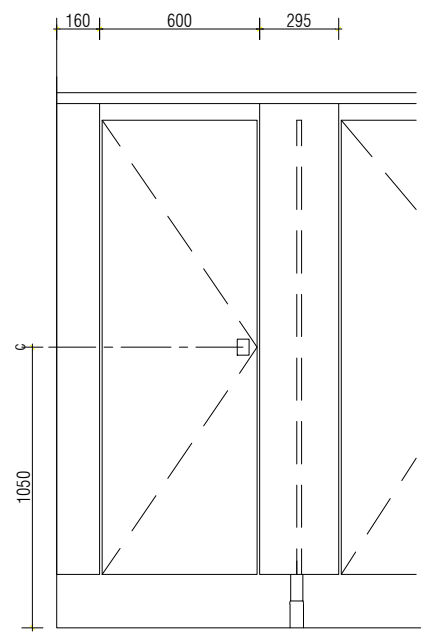

03 ELEVATION
1:10

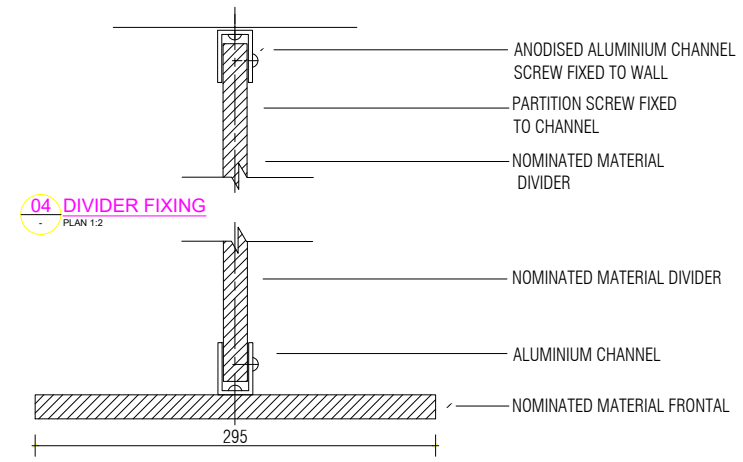

04 DIVIDER FIXING
PLAN 1:2

05 FRONTAL FIXING
PLAN 1:2

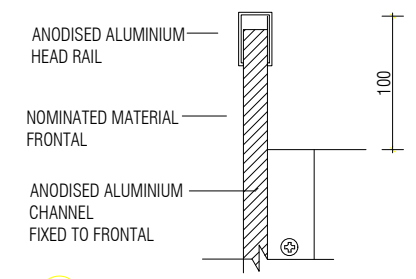

06 HEAD RAIL
DETAIL 1:2

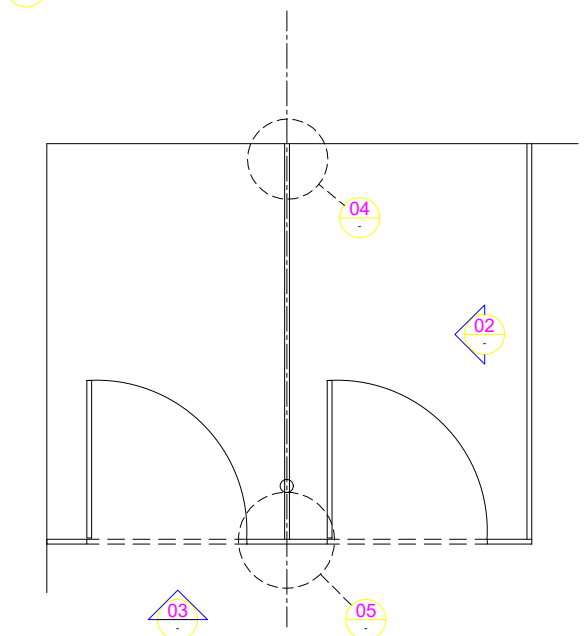

01 PLAN
1:10

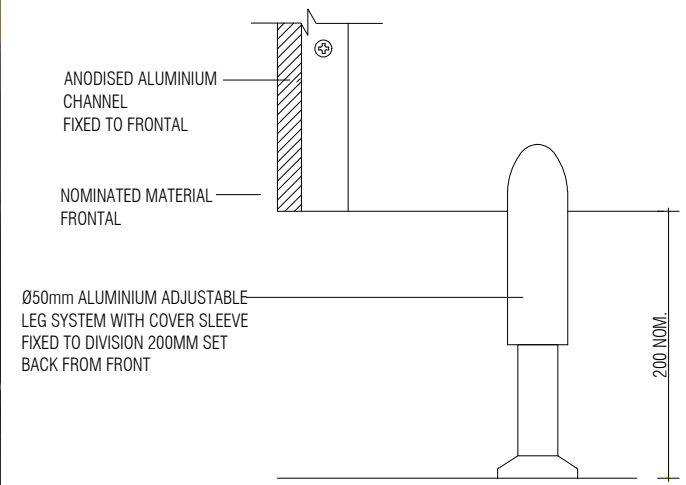

07 FLOOR LEG
SECTION 1:2

ISSUE	REVISION	DATE	APPD



Kirkbuild Commercial Joinery Pty Ltd

Shed3B, 160 Toongarra Rd
Wulkuraka QLD 4305

Ph: (07) 3496 7900
admin@kirkbuild.com.au
www.kirkbuild.com.au

JOB DESCRIPTION
Kirkbuild Yarra

DRAWING DESCRIPTION	DRAWN	CHECKED
Overhead Braced Leg Floor Mounted Partition System Nominated Material		

SCALE (AT A1)	DATE
As Shown	Oct 21

DRAWING NO.	ISSUE
Yarra	01

DO NOT SCALE DRAWING. VERIFY ALL DIMENSIONS AND LEVELS ON SITE