

02 ELEVATION
1:10

03 ELEVATION
1:10

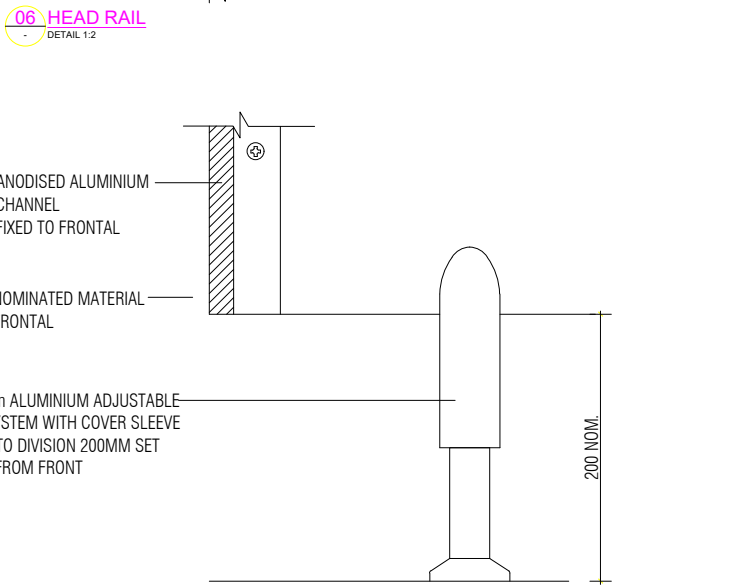

07 FLOOR LEG
SECTION 1:2

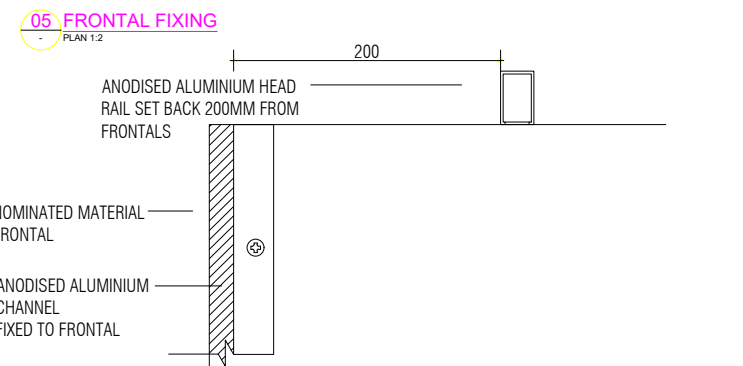
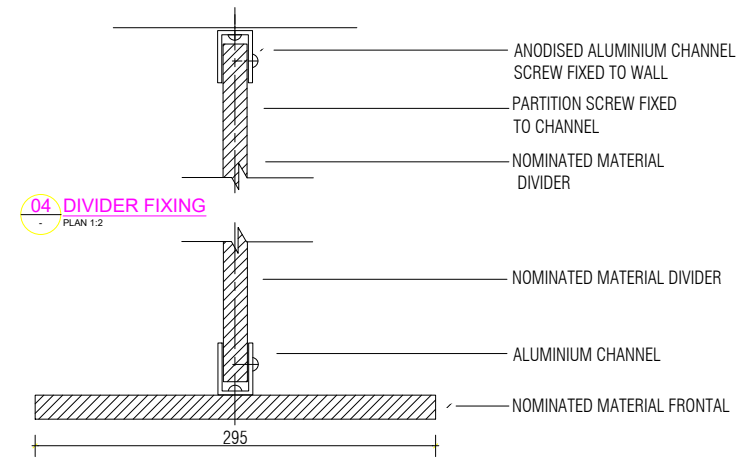
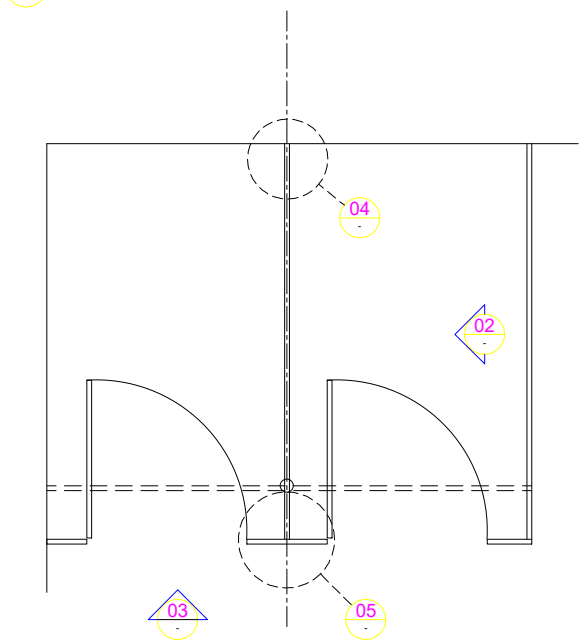

01 PLAN
1:10

ISSUE	REVISION	DATE	APPD



Kirkbuild Commercial
Joinery Pty Ltd

Shed3B, 160 Toongarra Rd
Wulkuraka QLD 4305

Ph: (07) 3496 7900
admin@kirkbuild.com.au
www.kirkbuild.com.au

JOB DESCRIPTION
Kirkbuild Swan

DRAWING DESCRIPTION	DRAWN	CHECKED
Set Back Overhead Braced Leg Floor Mounted Partition System Nominated Material		CHECKED

SCALE (AT A1)	DATE
As Shown	Oct 21

DRAWING NO.	ISSUE
Swan	01

DO NOT SCALE DRAWING. VERIFY ALL
DIMENSIONS AND LEVELS ON SITE