

02 ELEVATION  
1:10

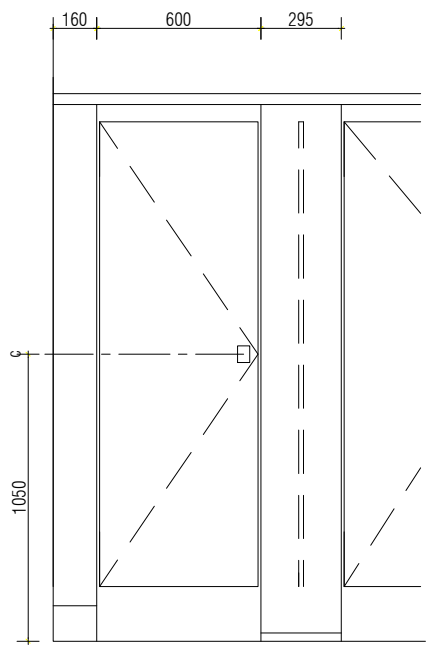

03 ELEVATION  
1:10

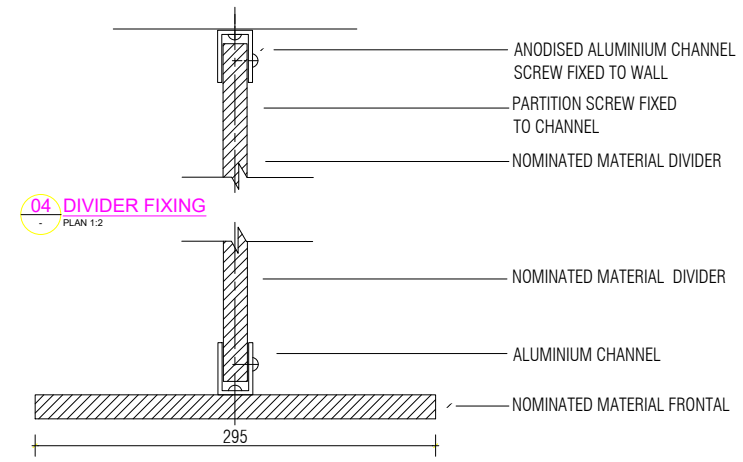

04 DIVIDER FIXING  
PLAN 1:2

05 FRONTAL FIXING  
PLAN 1:2

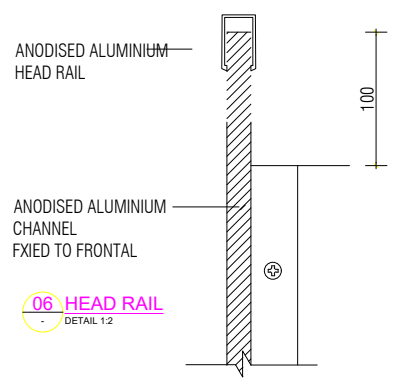

06 HEAD RAIL  
DETAIL 1:2

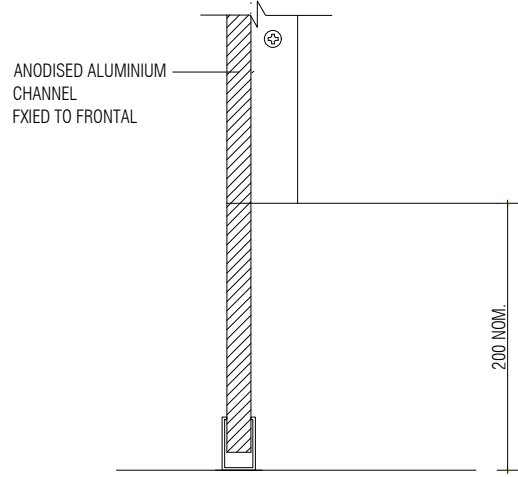

07 FLOOR LEG  
SECTION 1:2

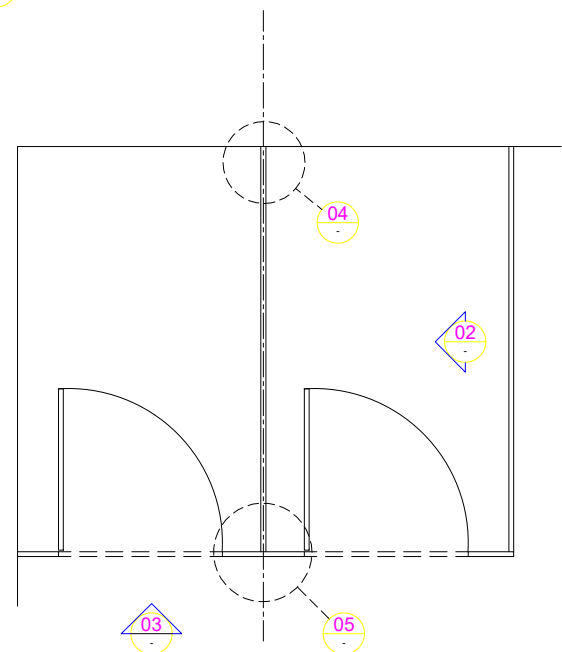

01 PLAN  
1:10

ISSUE	REVISION	DATE	APPD
XX	X	XX.XX.XX	XX



Kirkbuild Commercial  
Joinery Pty Ltd

Shed3B, 160 Toongarra Rd  
Wulkuraka QLD 4305

Ph: (07) 3496 7900  
admin@kirkbuild.com.au  
www.kirkbuild.com.au

JOB DESCRIPTION
Kirkbuild Finke

DRAWING DESCRIPTION	
Overhead Braced Floor Mounted Partition System Nominated Material	
DRAWN	CHECKED

SCALE (AT A1)	DATE
As Shown	Oct 21

DRAWING NO.	ISSUE
Finke	01

DO NOT SCALE DRAWING. VERIFY ALL DIMENSIONS AND LEVELS ON SITE