

MATERIAL SPECIFICATION & INSTALLATION GUIDE

PRODUCT ITEM CODE & DESCRIPTION

ML 994 CL ~ ACCESSIBLE COMPLIANT FOLDING SHOWER SEAT

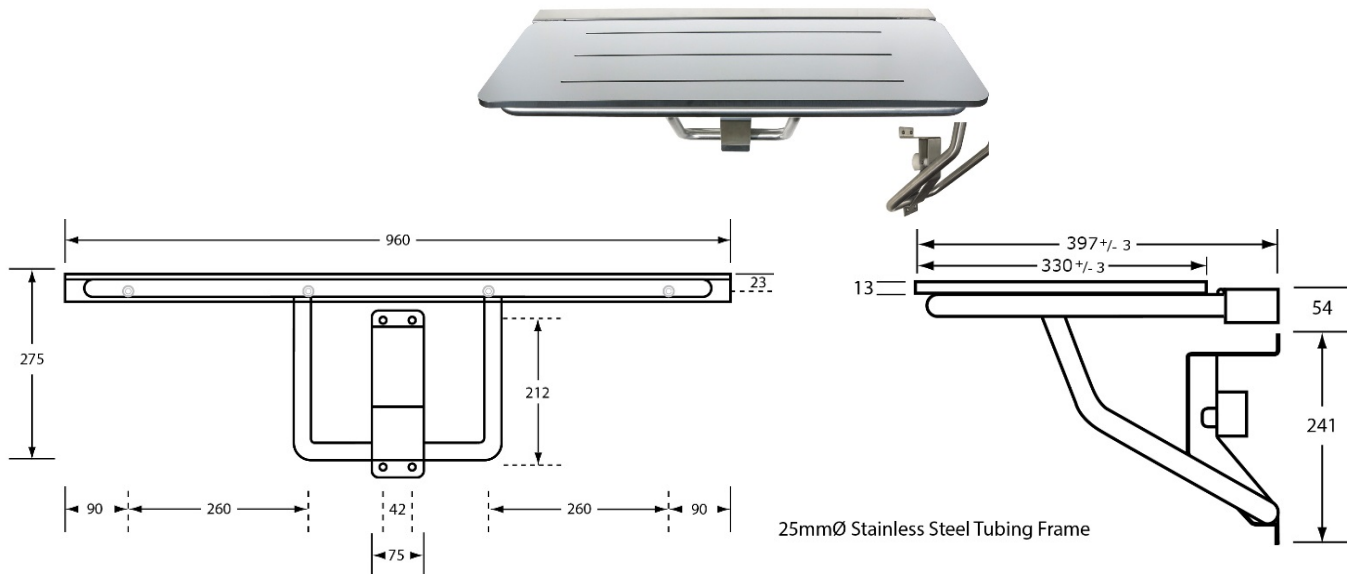

MATERIAL SPECIFICATIONS:

#304 grade stainless steel 25mm \emptyset tubing frame and support arm in #4 satin finish. Wall mount Guide Bracket - 16 gauge stainless steel / Folding seat fabricated from single piece 13mm thick, white Compact Laminate with burr free and rounded edges / Seat has 3 (three) bevelled slots for self-draining and slip resistance / As Compact Laminate has a black core, seat edges and drainage slots appear black (as illustrated). All materials and overall design provide for an accessible compliant, hygienic and high strength durable product.

DIMENSIONS:

Overall ~ 960mm W x 400mmD

INSTALLATION GUIDE:

Unit is to be surface mounted and is subject to BCA and/or AS 1428.1 (for able bodied and/or disabled use as may be applicable) for height location and fitment. Anchors are not included with the unit and are the responsibility of the installation contractor, as is the compliance re fitment of internal wall blocking, such as noggings for anchoring the unit via appropriate hardware.

NOT TO BE AFFIXED TO STEEL STUD WORK UNLESS OF A SOLID STRUCTURE

1. After determining appropriate height/location in shower cubicle area, place a small amount of "wet area" rated silicone sealant to rear of unit flanges, guide bracket and fixing hardware interface to inhibit water ingress into fixing area.
2. Fasten unit mounting and guide brackets to concealed anchor/noggings with appropriate hardware and test action for smoothness, ease of operation
3. Clean off any excess silicone, leave to cure/set for at least 24 hours before use.

Note: The locking mechanism for holding the seat in the retracted position is within the Guide Bracket. Accurate location of the Guide Bracket on the wall is imperative to the seat functioning properly.

These units should only be installed by a competent tradesperson and Metlam Australia takes no responsibility for any damage to walls or fixtures due to incorrect installation.

The photographs and line drawings of the products presented above are representational only.
Metlam Australia Pty Ltd reserves the right to, and from time to time, make changes and improvements in design and dimensions.