

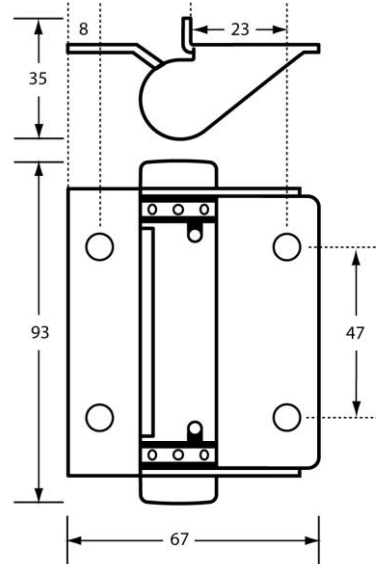

MATERIAL SPECIFICATION & INSTALLATION GUIDE

PRODUCT ITEM CODE & DESCRIPTION

209 ~ STAINLESS STEEL SPRING HINGE



COMPONENT MATERIALS / FEATURES:

#304 Stainless Steel Body #3 Finish / **NOTE:** When ordering ensure requirements are clearly stated for finish and for either HOLD OPEN or HOLD CLOSED, SCREW FIX or BOLT THROUGH - units can be universally mounted either LH or RH and can be either surface or flush mounted dependent upon installation needs

DIMENSIONS:

Overall ~ 67mm W x 93mm H x 35mm D

INSTALLATION:

1. May be subject to Australian Building Code Regulations or architectural drawings for height placement, which is the responsibility of the installer. It is recommended that each pair of hinges (two) carry no more than 50kg in load (weight) for effective operational longevity. Heavier doors will require multiple hinges to suit.
2. Measure & locate hinge fixture heights on door. Position leaf along the inner edge of the door with the pin barrel knuckles facing the side of the door that will open inwards. Mark and pre-drill door, (check out leaf area if flush mounting) then secure hinges with appropriate fasteners – NOTE: if SCREW FIX ensure screws are no greater than 90% in length of the material thickness being affixed to or, if BOLT THROUGH ensure Allthread ordered exceeds material thickness by at least 7mm either side for securing of dome nuts/washers. Recommendation is to use Loctite® or similar on BOLT THROUGH fixings.
3. Measure, level then pre-drill and hang door securing to jamb with relevant size/type screws.
4. Should the closing force need to be increased, please contact Metlam for instructions as necessary.

These units should only be installed by a competent tradesperson and Metlam Australia takes no responsibility for any damage to walls or fixtures due to incorrect installation.